

J4 is not on the edge of the board, so wiring is necessary.
 If the joystick board is the same of tape/sd-card, then just two wires are enough (power and ground already there).

If the Avnet 3A board is used, CLK pin is D3 and DATA is D4 on the 40 pin header.

Spartan Board

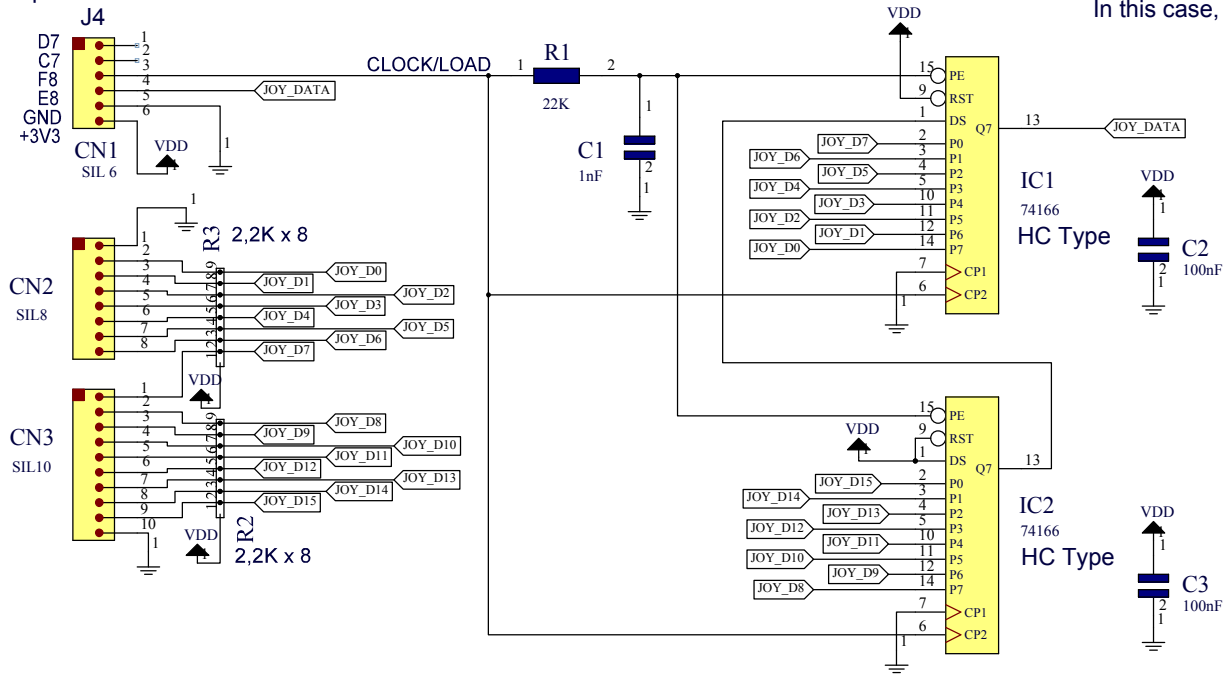

If 8 inputs are enough, IC2 can be omitted.
 In this case, PIN 1 of IC1 should be connected to +3,3V